

PRESSURE TRANSDUCER PTA

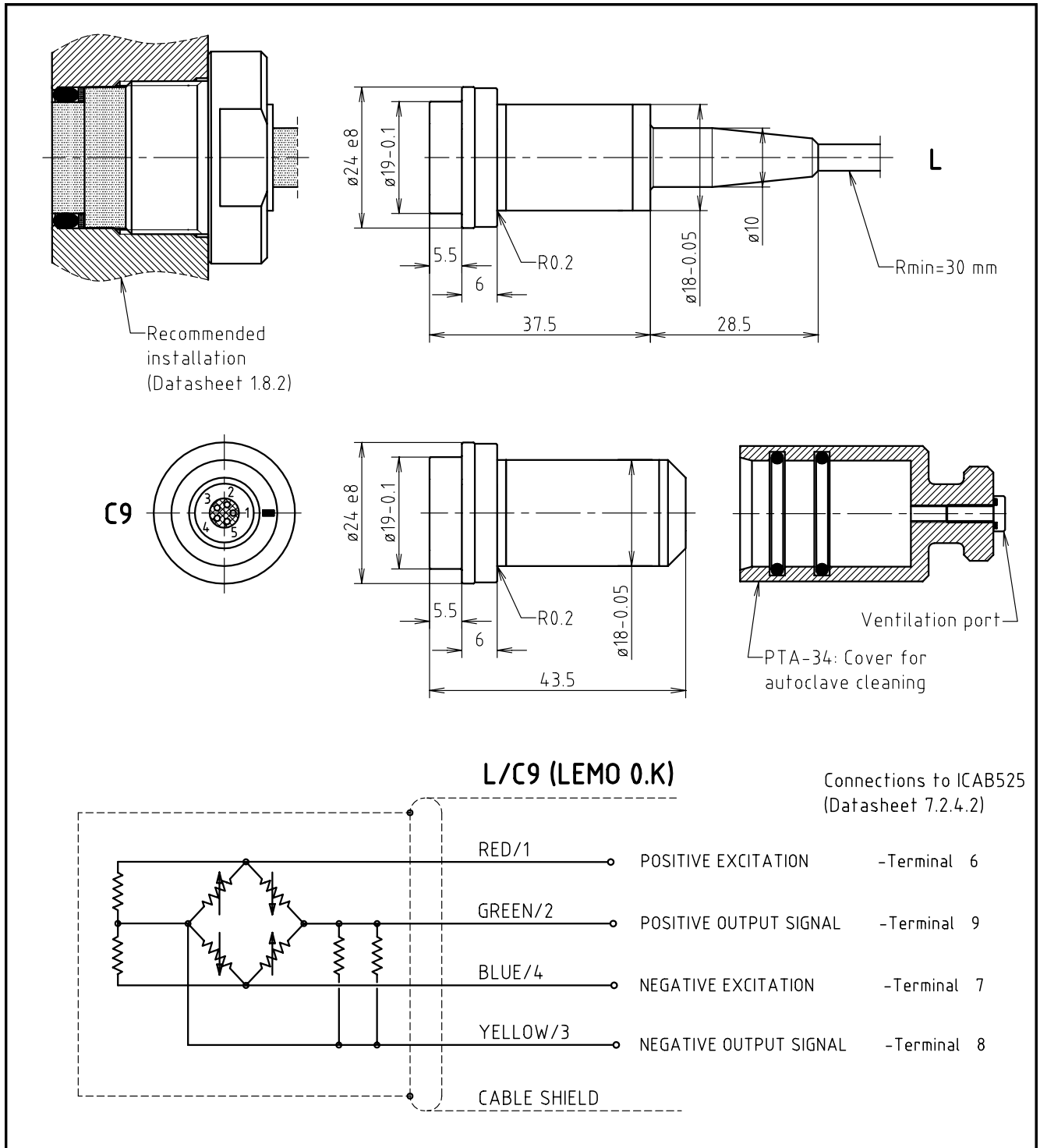

DESCRIPTION

The sensing element of the pressure transducer is a diaphragm machined out of titanium grade 5. On the inside of the diaphragm is mounted a strain-gauge, which converts the pressure generated deformation to a change in resistance. Titanium grade 5 is characterized by excellent corrosion data, very high 0.1% proof stress ($85\ kp/mm^2$), very little hysteresis and excellent long-term stability. Available with teflon cable or LEMO connection. The connector version allows the sensor to be autoclave cleaned provided the connector is protected by a cover.

SPECIFICATIONS

Standard ranges	10 or 20 bar gauge. 50, 100, 200, 500 or 1000 bar sealed reference.
Pressure limit	400 % without damage.
Excitation voltage	5 V nom. max. 10 V.
Input resistance	1000 Ω \pm 0.5 %.
Output resistance	800-1000 Ω .
Output signal	10 bar - 1000 bar: 2 mV/V \pm 2 %.
Zero balance	< \pm 2 % of FSO.
Non-linearity incl. hysteresis	< \pm 0.5 %, typical \pm 0.2 %.
Resonant frequency of diaphragm	Bar: 10 20 50 100 200 500 1000 kHz: 28 36 54 77 108 160 229
Temperature range	-55 °C to +150 °C.
Temperature coefficient of zeropoint	< 0.02 %/°C of FSO for 10 to 1000 bar.
Temperature coefficient of sensitivity	< 0.02 %/°C.
Vibration	Response less 0.05 % of FSO/g at 30 g peak 10-2000 Hz, limited by 12 mm double amplitude. 2 axis for 6 hours. IEC 68-2-6 Test Fc.
Mechanical shock	1000 g, 1 ms, 6 shocks will not affect calibration. IEC 68-2-27, Test Ea.
Material in contact with pressure media	Titanium grade 5.
Surface roughness (front)	< 0.4 μ m.
Weight	40 g.
Cable	Teflon cable, \varnothing 4.5 mm, 4 x 0.38 mm ² with shield (standard 2 metres).
Connector	LEMO, model EGG, series 0K, 5-pole female connector. Mating part: LEMO, model FGG, series 0K, 5-pole plug
Protection class	IP67 or better

INSTALLATION

The pressure transducer can be mounted in a HFJ adaptor (please see datasheet 1.8.2).

ORDERING INFORMATION

PTA x xx

L/x: Cable version with x meter cable length (standard 2 m).

C9: LEMO connector

Pressure range in bar.

PTA-34 Cover for cleaning