

# INDUSTRIAL 525 Hz CARRIER AMPLIFIER ICAB 525

The lid is connected to the box through 175mm ye/gn wire.

Connection through screw terminals.  
Wire size: max 1.5 mm<sup>2</sup>.

The aluminium enclosure may have the Protective Earth potential.

The cable shields must be connected to the housing inside the cable gland.

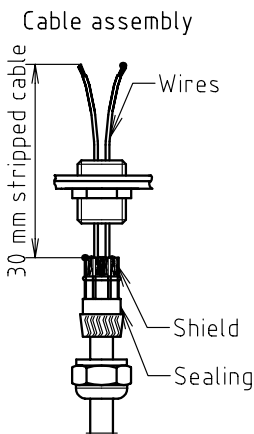
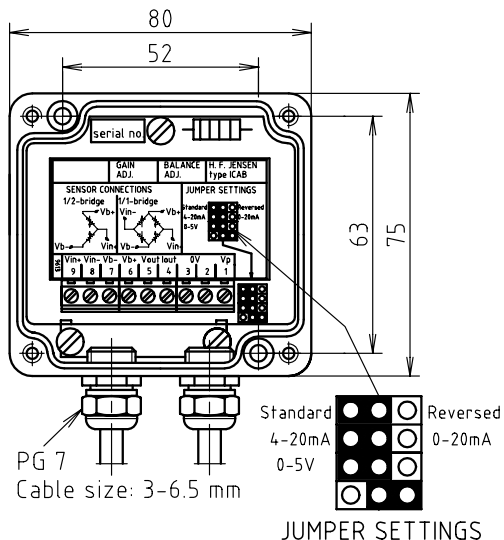

"LT": Only customer specified products.

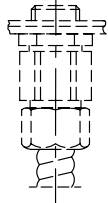

External Connections sign placed inside lid.

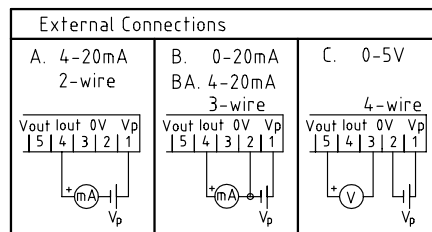

PCB Block diagram and Connection setups

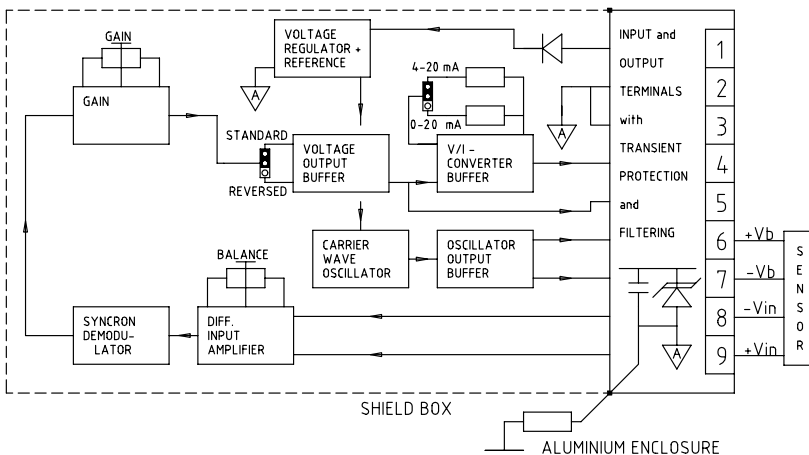

2-wire 4-20 mA load related to supply voltage

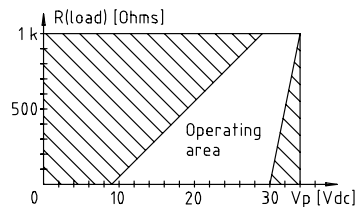

## DESCRIPTION

The ICAB industrial carrier wave amplifier is designed to interface the H. F. Jensen line of sensors or similar products based on a resistive, half- or full bridge measuring principle. The electronics includes an excitation oscillator, a true differential input amplifier, a phase-sensitive demodulator, low-pass filter and output stages. It will function over a wide range of supply voltage with no change in output. The product offers various output signals configured by the user through the jumpers on the PCB. Layout, filtered and transient protected connections plus a metal shieldbox covering all sensitive components ensures high electromagnetic compatibility. The EMC is further enhanced through shielded cable glands in the outer aluminium enclosure. This combination again features a robust and IP65 tight unit compatible with most industrial environments.

## SPECIFICATIONS

<b>Power requirement</b>	12-30 V <sub>DC</sub> , 4 mA <sub>DC</sub> + output signal current
<b>Supply voltage rejection</b>	min. 86 dB between 12 and 30 V <sub>DC</sub>
<b>Sensor excitation</b>	1-2 V <sub>RMS</sub> , max. 2 mA <sub>RMS</sub> , 525 Hz
<b>Output signals and load</b>	Selected by jumpers placed beside the terminals
- A	4-20 mA <sub>DC</sub> , 2-wire, R <sub>L</sub> : see diagram, C <sub>L</sub> < 1μF
- B	0-20 mA <sub>DC</sub> , 3-wire, R <sub>L</sub> < 700 Ω , C <sub>L</sub> < 1μF
- BA	4-20 mA <sub>DC</sub> , 3-wire, R <sub>L</sub> < 700 Ω , C <sub>L</sub> < 1μF
- C	0-5 V <sub>DC</sub> , 4-wire, R <sub>L</sub> > 20 kΩ , C <sub>L</sub> < 1μF
<b>Load resistance rejection</b>	min. 60 dB for max ΔR <sub>L</sub>
<b>Response time (0-100 %)</b>	60 msec.
<b>Output signal ripple</b>	< 0.05 % p-p of FSO
<b>Polarity S/R</b>	Selected by jumper placed beside the terminals
<b>Non-linearity</b>	< 0.01 %
<b>GAIN adjustment</b>	± 10 % of signal output
<b>BALANCE adjustment</b>	± 10 % of FSO
<b>Temperature range</b>	-25 °C to +85 °C
<b>Temperature coefficient</b>	< 0.01 %/°C of FSO
<b>Cable length</b>	max. 100 m between sensor and amplifier
<b>Environmental conditions</b>	
- vibration	According to IEC 68-2-6 (10-150 Hz, 0.35 mm/5g)
- shock	According to IEC 68-2-27 (1000 g half sine, 1 msec)
- electromagnetic immunity	According to EN 50082-2 (generic industrial standard)
- electromagnetic emission	According to EN 50081-2 (generic industrial standard)
<b>Materials and protection class</b>	Box of Al Si 12, IP65 - Cable glands of brass, IP67
<b>Weight</b>	400 gram

## INSTALLATION

If the ICAB is delivered together with a H. F. Jensen sensor the measuring system is factory calibrated with a small compensation network marked with the serial number of the sensor and followed by a "Certificate of Accuracy". The calibration should be checked after every new installation or service where parts have been changed. Extension cable between sensor and amplifier might change calibration. Connect the sensor and supply/output wires to the ICAB according to the connection diagram and check the output configuration. The total measuring system is designed to ensure high electromagnetic compatibility. To create the necessary protection, shielded cables must be used with shields connected inside the cable glands of the housing. Make sure the lid and cable gland nuts are tightened after connection.

## ADJUSTMENT

Let sensor be unactivated or in its ZERO state. Adjust BALANCE to the 0 % output signal value. Activate sensor to full-scale and adjust to 100 % output signal value with GAIN. Check output with sensor unactivated and repeat if necessary. With *Standard* output polarity the output signal increases for increasing input signal.

## ORDERING INFORMATION

ICAB 525 <sup>x x</sup>

\_\_\_\_\_ Input signal [mV/V]

\_\_\_\_\_ Output signal configuration: A/B/BA/C (please see SPECIFICATIONS).